

TYSONIC NON-SPILLABLE SEALED RECHARGEABLE BATTERY

TY12200 12V, 20.0Ah

☆ SPECIFICATION

- NOMINAL VOLTAGE : 12 V
- NOMINAL CAPACITY(20 hrs) : 20.0 Ah
- DIMENSIONS
 - TOTAL HEIGHT : 167 mm (6.58 inches)
 - CONTAINER HEIGHT : 167 mm (6.58 inches)
 - LENGTH : 181 mm (7.13 inches)
 - WIDTH : 76 mm (2.99 inches)
- WEIGHT : APPROX 6.06 Kg (13.36 lbs)
- MAX DISCHARGE CURRENT : 200 A (5 sec)
- STANDARD TERMINALS : FP-01
- CONTAINER MATERIAL : GENERAL GRADE ABS
: FLAME RETARDANT ABS

☆ CHARACTERISTICS

- CAPACITY 25 C / 77 F
 - 20 hr @ 1.0 A : 20.0 Ah
 - 5 hr @ 3.2 A : 16.0 Ah
 - 1 hr @ 12.0 A : 12.0 Ah
 - 1 C @ 20.0 A : 10.0 Ah
- INTERNAL RESISTANCE() : 13 mΩ @ 25°C, 77 F Ω
- CHARGING VOLTAGE (25C, 77 F°)
 - STANDBY USE : 2.2750.025 V/CELL
 - : (-3.3mV / C / CELL)
 - CYCLE USE : 2.450.05 V/CELL
 - : (-5 mV / C / CELL)
- MAX CHARGING CURRENT : 6.0 A

Discharge Characteristics 25 C (77 F)⁰

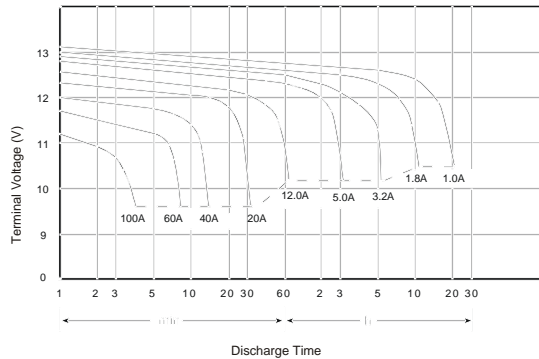

Discharge Current vs Time

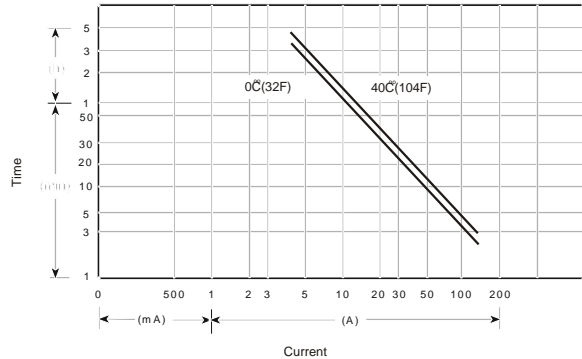

☆ Dimensions

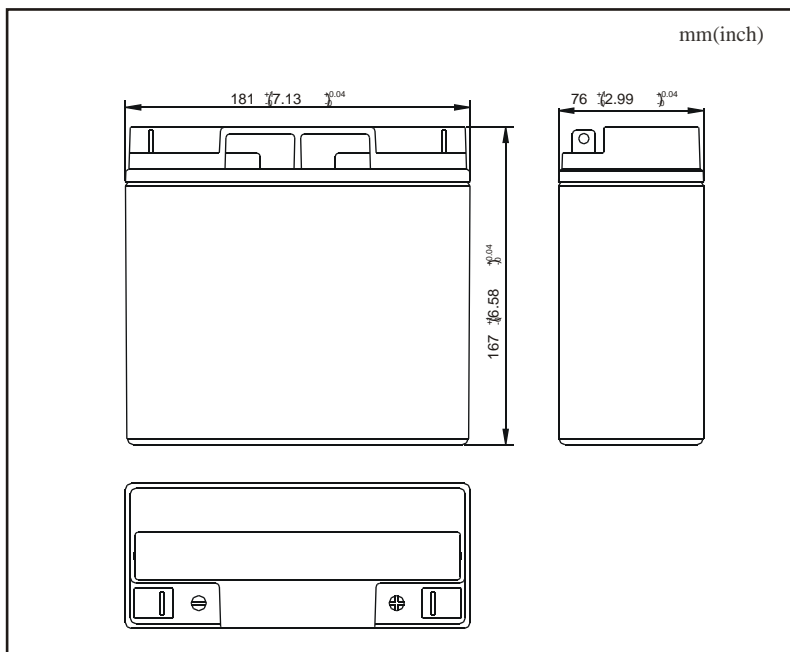

☆ Terminal

