

stored energy solutions for a demanding world



Model: **GFM2000**

GFM Series

The GFM range of gel technology batteries offers outstanding performance including a 15+ years design life. The GFM series is designed by using the polymer gel electrolyte and compliant with the latest IEC60896-21/22 standard. This GFM series also offers 100% capacity out of the box and is capable of handling deep discharges for complete peace of mind. The multiple installations to both horizontally and vertically are easily accessible due to the flexible connectors design.



Specifications

Battery Model	GFM2000			
Nominal Voltage	2V			
Capacity (25°C)	10HR (200A, 1. 80V)	3HR (500A, 1. 80V)		1HR (1100A, 1. 75V)
	2000AH	1500AH		1100AH
Dimensions	Length	Width	Height	Total Height
	349mm	233mm	555mm	566mm
Approx. Weight	122kg			
Internal Resistance	0. 11mΩ			
Max Charge Current Allowed	500A			
Charge Voltage (25°C)	Cycle use		Float use	
	2. 35V/cell		2. 25V/cell	
Temperature Ranges	Operation (maximum): -40°C to 55°C(-40°F to 131°F)			
	Operation (recommended): 15°C to 25°C(59°F to 77°F)			
	Storage: -20°C to 40°C(-4°F to 104°F)			
Terminal	M8 Female			
Terminal Hardware Torque	15 ± 1. 0Nm			
Container Material	ABS (V0 optional)			

Constant Current Discharge Characteristics Units: Amperes (25°C, 77°F)

End voltage per cell	5min	15min	30min	1hr	2hr	3hr	5hr	6hr	8hr	10hr	24hr	48hr	100hr
1. 60V	2910. 1	2448. 6	1989. 8	1311. 3	807. 5	592. 8	383. 7	330. 6	258. 8	212. 2	98. 3	52. 5	29. 4
1. 65V	2728. 9	2304. 8	1814. 7	1237. 7	784. 5	576. 9	379. 0	326. 6	256. 6	211. 0	96. 9	52. 1	29. 0
1. 70V	2564. 6	2181. 0	1659. 5	1176. 0	757. 6	550. 9	369. 5	318. 8	252. 9	207. 7	96. 5	51. 7	28. 6
1. 75V	2419. 3	2052. 9	1530. 2	1102. 5	729. 7	538. 3	363. 2	314. 1	249. 4	205. 9	95. 7	51. 0	27. 8
1. 80V	2285. 6	1914. 5	1432. 7	1045. 9	707. 8	521. 6	352. 4	305. 7	242. 7	203. 2	93. 6	50. 2	26. 9
1. 85V	1962. 3	1628. 5	1259. 5	931. 2	638. 0	482. 8	332. 6	291. 1	234. 9	194. 9	90. 9	47. 8	26. 0
1. 90V	1607. 1	1285. 7	1046. 6	765. 4	533. 3	429. 2	301. 2	262. 6	211. 8	177. 6	84. 9	44. 6	24. 0

Discharge Data with Constant Power Units: Watts per cell (25°C, 77°F)

End voltage per cell	5min	15min	30min	1hr	2hr	3hr	4hr	5hr	6hr	8hr	10hr	24hr
1. 60V	5635. 6	4719. 9	3758. 2	2676. 2	1726. 7	1279. 0	1020. 0	844. 8	721. 5	564. 0	460. 5	207. 6
1. 65V	5359. 9	4529. 5	3554. 7	2472. 8	1584. 1	1200. 3	967. 5	815. 3	698. 6	543. 1	449. 4	203. 7
1. 70V	5153. 1	4368. 7	3466. 1	2354. 8	1538. 1	1157. 7	934. 7	796. 9	684. 8	531. 3	436. 2	199. 7
1. 75V	4992. 3	4204. 6	3347. 9	2262. 9	1483. 7	1115. 1	915. 0	777. 3	669. 0	511. 6	429. 6	197. 8
1. 80V	4854. 4	4007. 6	3229. 7	2210. 5	1456. 1	1075. 7	885. 5	755. 6	649. 4	498. 5	423. 1	194. 8
1. 85V	4414. 6	3649. 9	2872. 0	2010. 4	1338. 1	1018. 6	851. 4	720. 2	614. 9	482. 1	406. 7	186. 9
1. 90V	3896. 0	3167. 4	2422. 3	1731. 6	1161. 0	944. 5	792. 7	673. 0	574. 6	451. 0	377. 2	175. 1

stored energy solutions for a demanding world



Model: **GFM2000**

GFM Series

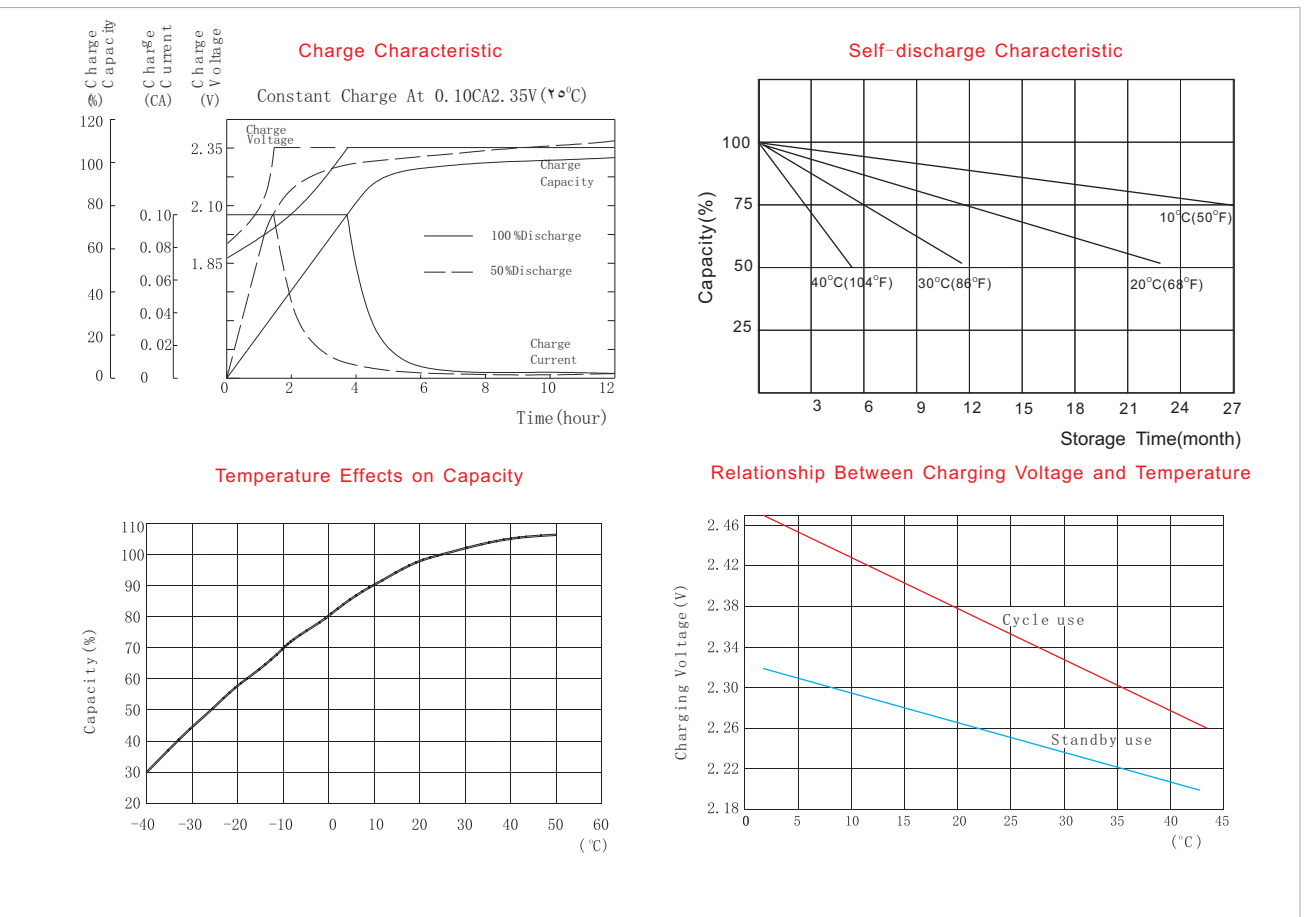
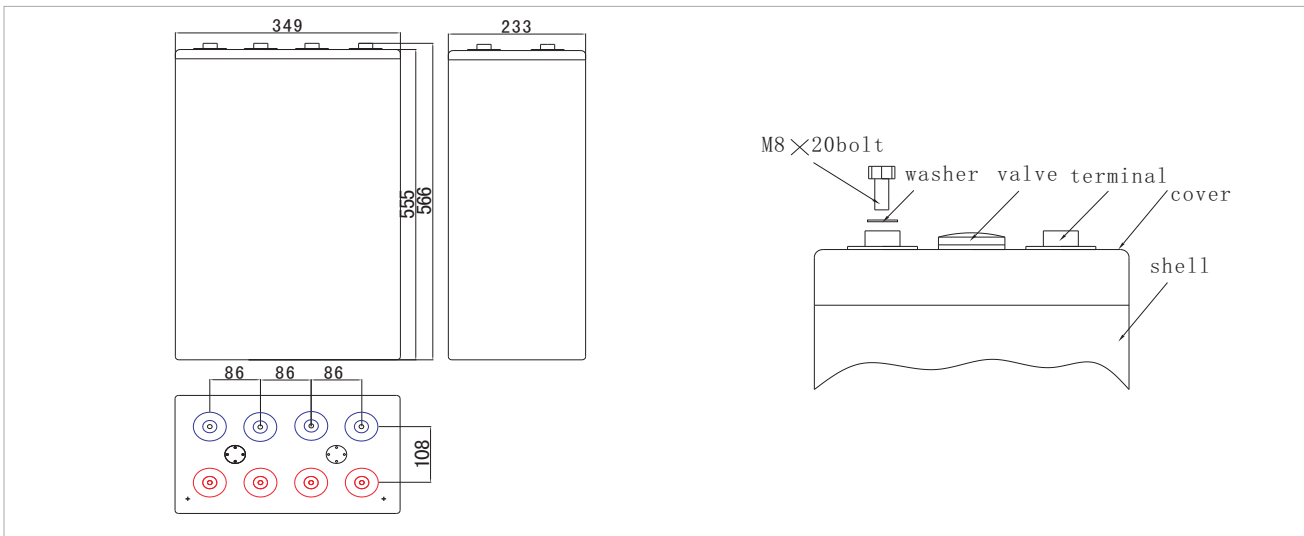

TYSONIC BATTERY INC.

1032 East Main Street . Alhambra, CA 91801 USA
 Toll Free: 877-897-6648 . Tel: (626) 289-5962 . Fax: (626) 576-2503
<http://www.tysonicbattery.com> . Email: info@tysonicbattery.com

