

TYSONIC TY-SC-4200

单颗电池规格 Specifications of single cell

标称电压 Nominal voltage		1.2V	
容量 Capacity		0.2C 放电 Discharge	30A 放电 Discharge
	最小 Minimum	300min	7.1min
	典型 Typical	310min	7.5min
尺寸 Dimensions	直径 Diameter	mm 23.0 ^{-0.7}	
	高 Height	44.0 ^{-1.0}	
大约重量 Weight (Approximately)		克 gram 72.0	
电阻 Internal Impedance At 1000 Hz		8mΩ(Max) (充电后 After Charge)	
充电 Charge	标准 Standard	420mA(0.1C)×15hrs	
	快速 Rapid	2100mA(0.5C)×2.1hrs	
环境温度 Ambient temperature	充电 Charge	标准 standard	0°C to 40°C
		快速 Rapid	0°C to 40°C
	放电 Discharge		-20°C to 50°C
	贮藏 Storage		-20°C to 30°C

典型特征 Typical characteristics

标准充电特征 Standard charge

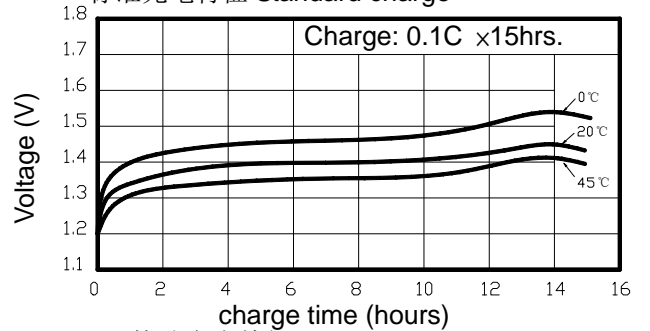

快速充电特征 Rapid charge

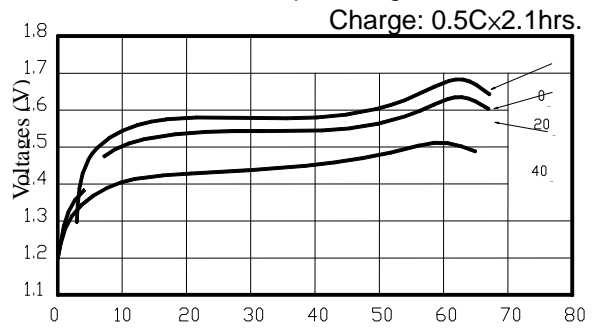

放电特征 Discharge characteristics

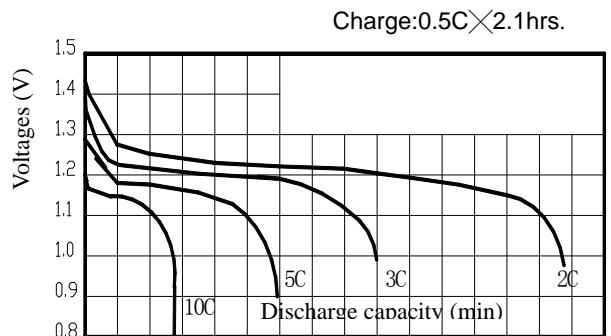

MPV (V)

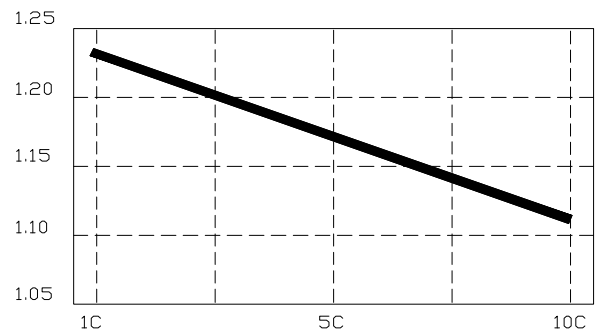

Charge retention curves of Ni-MH cylindrical cell At various storage temperature

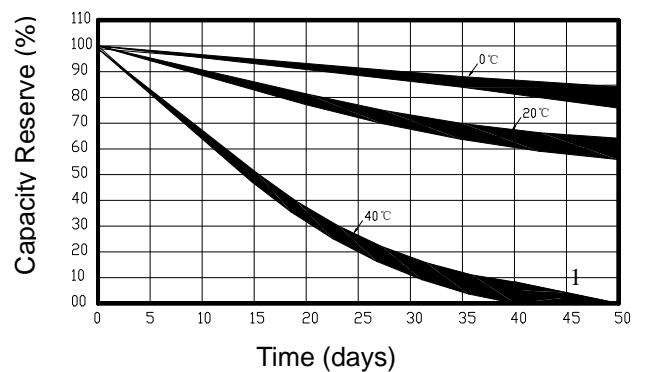

单颗电池尺寸包括 PVC (Dimensions with tube)

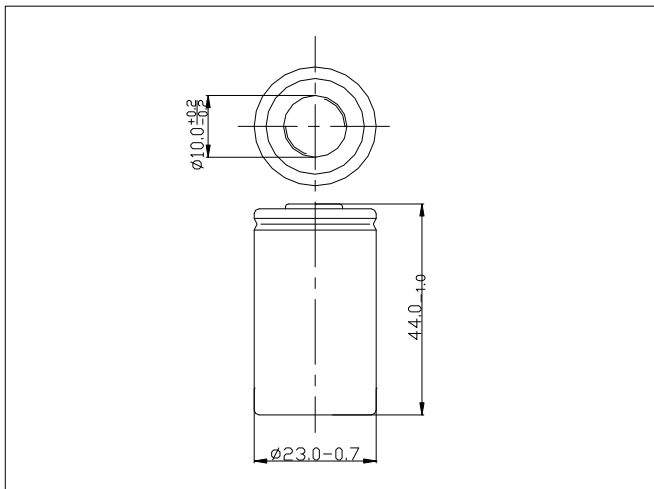

备注 Note:

1. 标称容量是指 20°C 时 0.2C 放电容量
Nominal capacity, rated at 0.2C 20°C.
2. 容量只作为参考
Average capacity, for reference only.
3. 重量和内阻也作为参考
Weight and internal impedance are For reference.
4. 寿命测试依照 IEC 标准
Standard according as IEC of test cycle life.

BAO TONG USA INC. dba TYSONIC BATTERIES

1. PREFACE

The specification is suitable for the performance of NI-MH rechargeable battery produced by **Bao Tong USA Inc. dba TYSONIC BATTERIES**.

2. MODEL

TY-SC-4200

3. APPEARANCE

There shall be no such details as discoloration or electrolyte leakage or 0 voltage.

4. RATINGS

Description	Unit	Specification	Condition
Nominal Voltage	V	1.2	Unit cell
Typical Capacity	min	7.5	Discharge at 30A to 0.8V
Nominal Capacity	mAh	4200	Standard Charge/Discharge
Minimum Capacity	min	7.1	Discharge at 30A to 0.8V
Standard Charge	mA	420(0.1C)	Ta=0~40°C
	hour	15	
Fast Charge	mA	840(0.2C)~2100(0.5C) with charge termination control	-ΔV=5mV/ cell Timer cutoff=105%input capacity Temp. cutoff=40~45°C dT/dt=0.8°C/min(0.5 to 1.0C); 0.8~1°C/min(1C)
	hour	6.0 approx.(0.2C) 2.1 approx(0.5C)	
Trickle Charge	mA	210(0.05C)~420(0.1C)	Ta=0~40°C (see note 1)
Maximum Discharging Current	A	30(Continuous) 50(Momentary)	Ta =0~50°C 0.8v cut off
Storage Temperature	°C	-20~+25(within 1 year) -20~+30(within 3 month) -20~+40(within 1 month) -20~+50(within 1 week)	*
Typical Weight	g	72 approx	*

5. PERFORMANCE

Before proceed the following tests, the cells should be discharged at 0.2C to 1.0V cutoff. Unless otherwise stated, tests should be done within one month of delivery under the following conditions:

Ambient temperature: 20°C ± 5°C

Relative Humidity: 65 ± 20%

Standard Charge/Discharge Conditions:

Charge: 420 mA(0.1C) × 15hrs

Discharge: 840mA(0.2C) to 1.0V/cell

Test	Unit	Specification	Condition	Remarks
Capacity	min	≥ 7.1	Discharge at 30A to 0.8V	Up to 3 cycles are allowed
MPV	V	≥ 1.12	Discharge at 30A to 0.8V	Up to 3 cycles are allowed
Open circuit Voltage (OCV)	V	≥ 1.25	Within 1 hr after standard charge	Unit cell
Internal Impedance (Ri)	m Ω	≤ 8	Upon fully charge at 1kHz	*
Low Temperature Discharge	min	≥ 240	Standard Charge, Storage:24hrs at 0 \pm 2 $^{\circ}$ C 0.2C discharge at 0 \pm 2 $^{\circ}$ C	1.0V/cell Cut-off
Overcharge	N/A	No conspicuous deformation and/or leakage	0.1C charge for 48hrs	*
Charge reserve	min	≥ 180 min	Standard charge Storage: 28 days Standard discharge (0.2C)	1.0V/cell Cut-off
IEC Cycle Life Test	Cycle	≥ 500	IEC61951-2(2003)7.4.1.1	*
Humidity	N/A	No leakage	Standard charged, stand for 14 days at 33 \pm 3 $^{\circ}$ C and 80 \pm 5% of relative humidity	*
External Short Circuit	N/A	No fire and no explosion	After standard charge, short-circuit the cell at 20 $^{\circ}$ C \pm 5 $^{\circ}$ C until the cell temperature returns to ambient temperature.(cross section of the wire or connector should be more than 0.75mm ²)	*
Safety Device Operation	N/A	No explosion	Forced discharge at 0.2C to a final voltage of 0V,then the current be increased to 1C and forced discharge continue for 60 min	Leakage of electrolyte and Deformation are acceptable
Free falling(drop)	N/A	$\Delta V < 0.02$ V/cell $\Delta Ri < 5\%$ /cell	Charge at 0.1C for 16hrs,and then leave for 24hrs,check battery before / after drop Height: 50 cm Thickness of wooden board: 30mm Direction is not specified Test for 3 times	*